

## PARTS

VARIOUS PARTS FOR STAY-ASSEMBLING

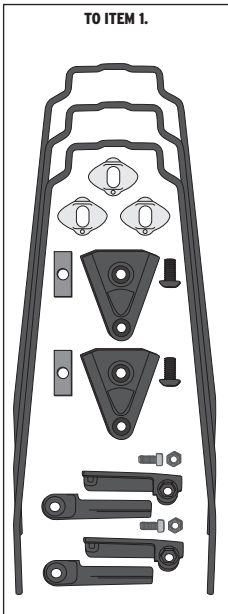

VARIOUS PARTS FOR MOUNTING THE FENDERS

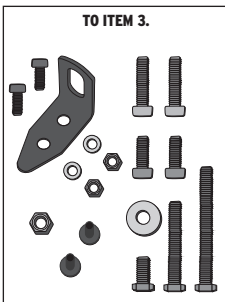
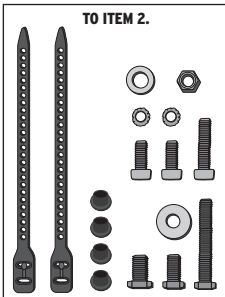

SPACERS FOR:  
- FORKS WITH DISC BRAKES  
- FRAME MOUNTING REAR  
OPTIONAL



### ATTENTION!

KEEP THE MINIMUM DISTANCE OF 15 MM BETWEEN FENDER AND TYRE.

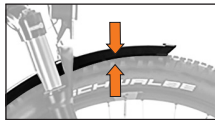

## 1. STAY-ASSEMBLING FRONT + REAR

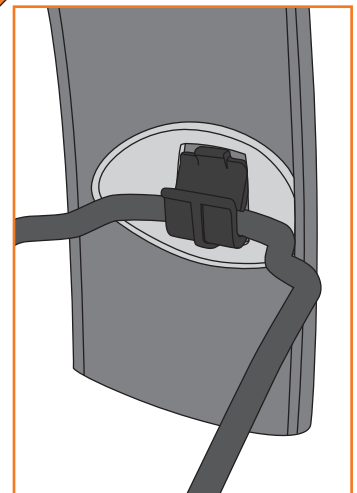
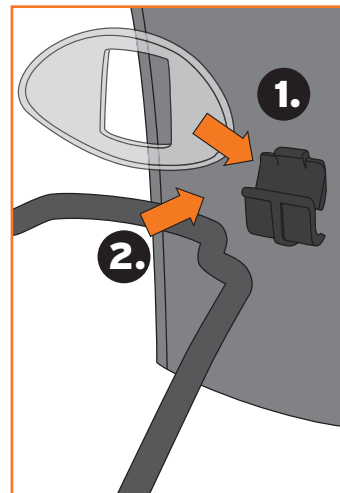
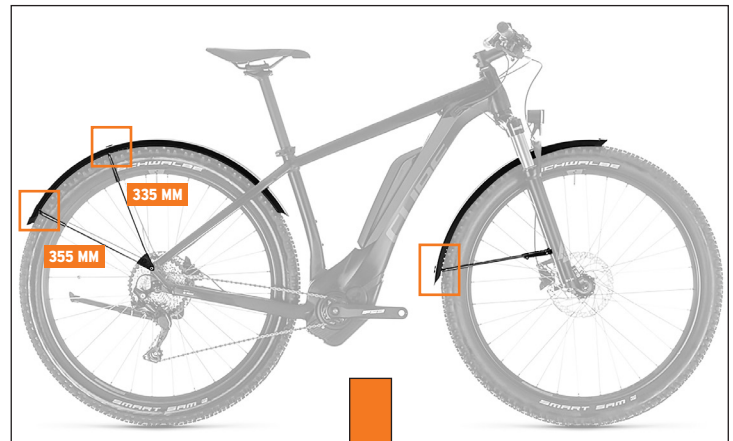
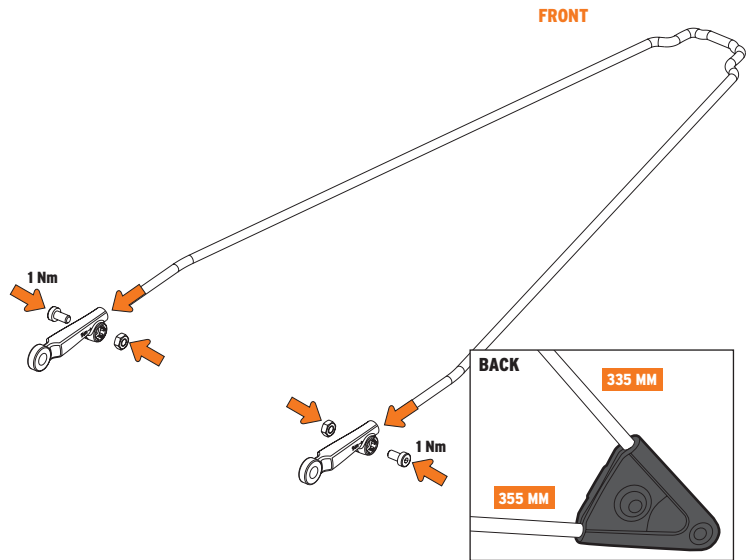

### EN. BLUEMELS 75 U

Proprietary construction, in which super-fine aluminium strips are embedded in a matte black plastic coating make these mudguards extremely durable, resistant to bending and UV damage.



## 2. FRAME MOUNTING FRONT

### 2.1 MOUNTING THE FRONT PLUGS

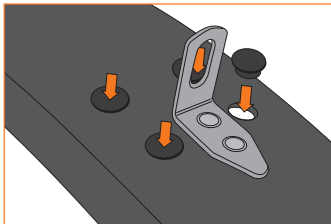

### 2.1.1 BRACKET-FITTING FRONT

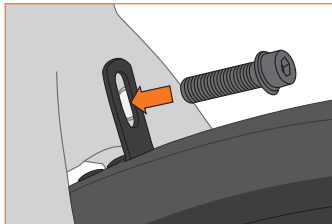

### 2.2 OPTIONAL FITTING STRAPS FRONT

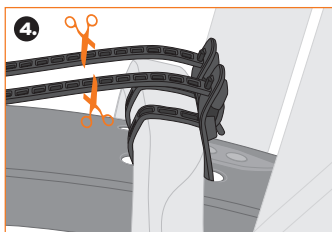
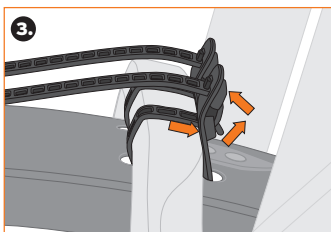
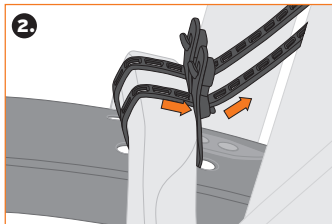
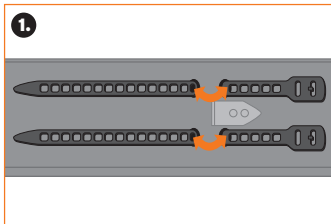

### 2.3 STAY ATTACHMENT FRONT INCL. LENGTHS ADJUSTMENTS OF THE STAYS

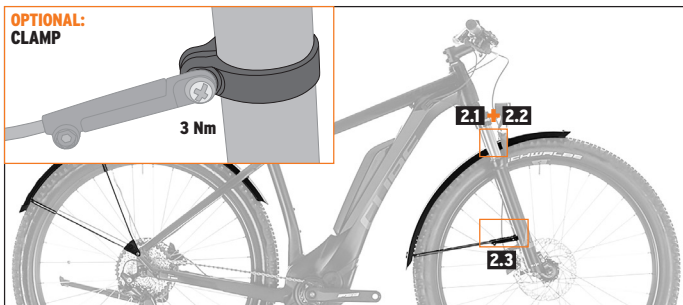
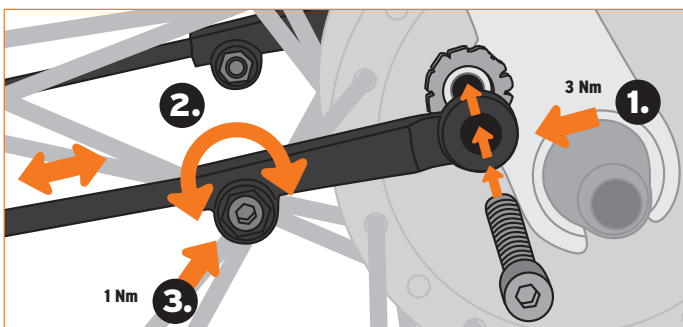

## 3. FRAME MOUNTING REAR

### 3.1 REMOVE THE REAR WHEEL

### 3.2 MOUNTING THE REAR MUDGUARD ONTO THE FRAME DIRECT BY SCREWING IT ON AT AN ANGLE OF 0°

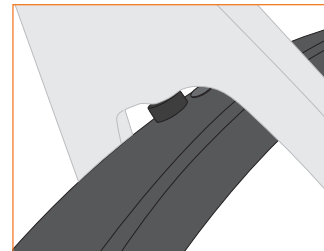
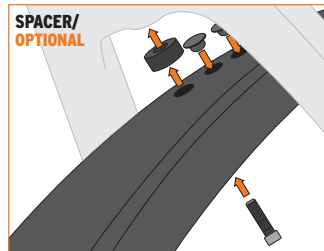

### 3.3 MOUNTING WITH AN ANGLE OF 90°

#### 3.3.1 SCREW THE BRACKET

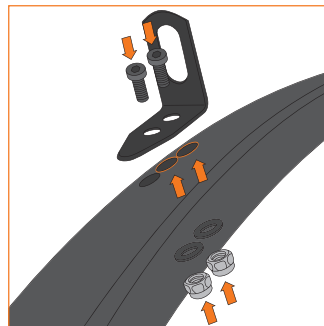

#### 3.3.2 SCREW THE FENDER ON THE FRAME

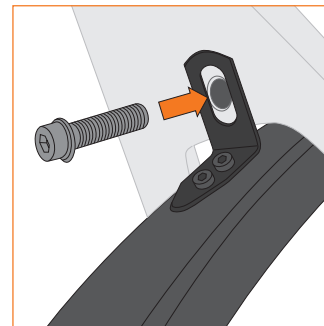

### 3.4 REMOUNT THE REAR WHEEL

### 3.5 REAR STAY ASSEMBLING

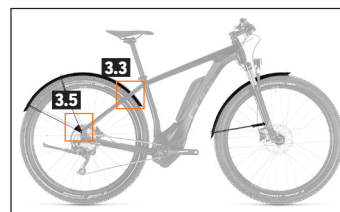
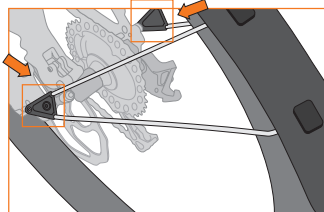

### 3.5.1 STAY ATTACHMENT REAR INCL. LENGTHS ADJUSTMENTS OF THE STAYS

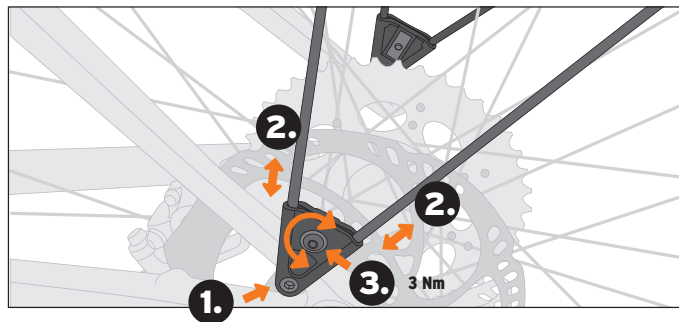

### ATTENTION OPTIONAL! MOUNTING OF SPACERS FOR FRAMES WITH DISC BRAKES

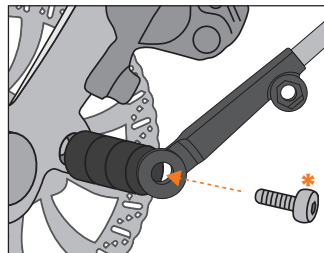

\* SCREW IS NOT INCLUDED IN THE SCOPE OF DELIVERY